

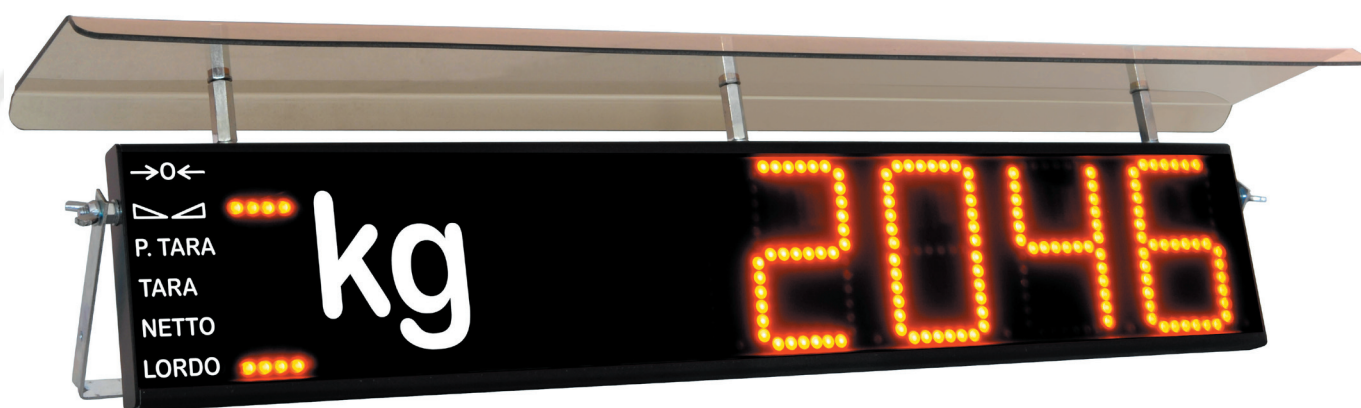

# Ripetitore di peso

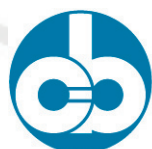

modello **RD100HL**



SOCIETA' COOPERATIVA  
**BILANCI AI**

# Ripetitore di peso RD100HL

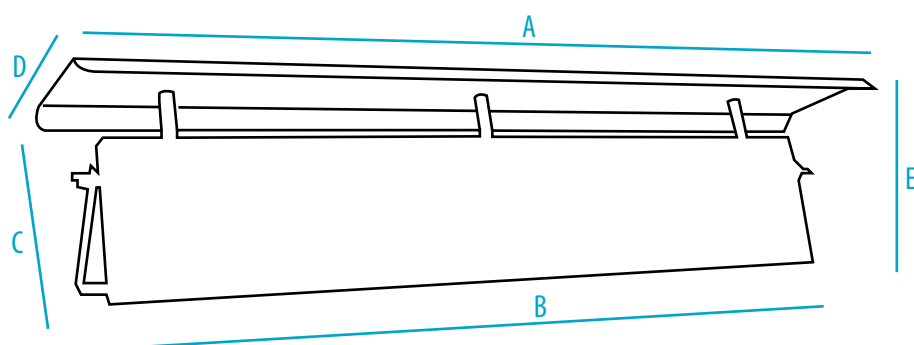

	RD100HL
A	740
B	665
C	120
D	130
E	160

## Caratteristiche generali

Display supplementare, non omologato, ad altissima intensità collegato al terminale elettronico di pesatura.  
Semplice e versatile, visibile fino ad elevate distanze è particolarmente consigliato per installazioni all'aperto.  
Collegabile a tutti i terminali di pesatura Coop Bilanciai.

## Caratteristiche tecniche

	RD100HL
Alimentazione	220 V tramite trasformatore di sicurezza
Display	4" (100 mm) a LED
Digit	6 digits
Tipo di trasmissione	RS232/422/485
Peso	1,7 kg



**SOCIETA' COOPERATIVA  
BILANCI**

Strumenti e Tecnologie per Pesare

41011 Campogalliano (MO) - Via S. Ferrari, 16  
Tel. 059.89.36.11 r.a. - Fax 059.52.70.79  
www.coopbilanciai.it - cb@coopbilanciai.it